

Project _____
 Item _____
 Quantity _____
 FCSI section _____
 Approval _____
 Date _____

Convotherm mini easyTouch Marine

- 6.06
- 6 shelves GN 2/3
- Marine
- Electric
- Injection/Spritzer
- Right-hinged door



Key features

- Cooking methods: Steam, Combi-steam, Convection, Rethermalization
- Extra functions:
 - Crisp&Tasty – 3 moisture-removal settings
 - HumidityPro – 3 humidity settings
 - BakePro – 3 levels of traditional baking
 - Reduced fan speed and auto-reverse mode
- easyTouch 7" TFT HiRes glass touch display (capacitive)
- ConvoClean+ system, fully automatic cleaning system with three intensity levels and Express mode
- Safe Cool Down function before cleaning
- HygieniCare
- WiFi and Ethernet interface (LAN)
- USB port integrated in the control panel
- TriColor indicator ring – indicates the current operating status
- Steam generated by injecting water into the cooking chamber
- Right-hinged appliance door with sure-shut function
- Door holding catch
- Rack with securing bar
- Maritime flanged feet for bolting or welding to the supporting surface in case of rough weather

Standard features

- Cooking methods:
 - Steam (30-130°C) with guaranteed steam saturation
 - Combi-steam (30-250 °C) with automatic moisture control
 - Convection (30-250 °C) with optimized heat transfer
 - Regenerating function
- Operation of easyTouch user interface:
 - 7" TFT HiRes glass touch display (capacitive)
 - Smooth-action, quick-reacting scrolling function
- Climate Management
 - HumidityPro
 - Crisp&Tasty
- Quality Management
 - Airflow Management
 - BakePro
 - Multi-point core temperature probe
 - Preheat and cool down function
- Cleaning Management
 - ConvoClean+ fully automatic cleaning system with 3 intensity levels, with a Clean and Care Booster
 - 10-minute Express cleaning
 - 2-minute QuickRinse (rinse with water)
 - Safe Cool Down function before cleaning (when door is closed)
 - Cleaning profiles can be set individually as favourites
 - Cleaning calendar
- HygieniCare
 - Hygienic handles (door and hand-shower handles)
 - Hygienic Steam function
 - Hygienic touch film

Standard features

- Production Management
 - Automatic cooking with Press&Go with up to 399 profiles
 - Integrated cookbook with 7 different categories
 - TrayTimer – load management for different products at the same time (manual mode)
 - TrayView – Load management for automatic cooking of different products using Press&Go
 - Favorites management
 - HACCP data storage
 - WiFi and Ethernet interface (LAN)
 - ecoCooking – energy-save function
 - Low-temperature cooking / Delta-T cooking
 - Cook&Hold – cook and hold in one process
 - Auto Start
 - Add steam
 - Regenerate – flexible multi-mode rethermalization function with preselect
 - Flexible shelf spacing
 - Automatic cooling during cooking and baking (for optional activation)



Convotherm mini
easyTouch Marine

- 6.06
- 6 shelves GN 2/3
- Marine
- Electric
- Injection/Spritzer
- Right-hinged door



Key features

- Cooking methods: Steam, Combi-steam, Convection, Rethermalization
- Extra functions:
 - Crisp&Tasty – 3 moisture-removal settings
 - HumidityPro – 3 humidity settings
 - BakePro – 3 levels of traditional baking
 - Reduced fan speed and auto-reverse mode
- easyTouch 7" TFT HiRes glass touch display (capacitive)
- ConvoClean+ system, fully automatic cleaning system with three intensity levels and Express mode
- Safe Cool Down function before cleaning
- HygieniCare
- WiFi and Ethernet interface (LAN)
- USB port integrated in the control panel
- TriColor indicator ring – indicates the current operating status
- Steam generated by injecting water into the cooking chamber
- Right-hinged appliance door with sure-shut function
- Door holding catch
- Rack with securing bar
- Maritime flanged feet for bolting or welding to the supporting surface in case of rough weather

Options

- Left-hinged appliance door
- Available in various voltages
- Safety door latch (with sure-shut function and venting position)

Accessories

- Hand shower with infinitely variable flow adjustment
- kitchenconnect®
- Stands in various sizes and designs
- Stacking kits with maritime feet
- Care products for the ConvoClean system fully automatic cleaning system

Front view

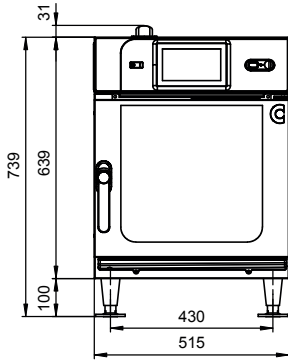

Side view

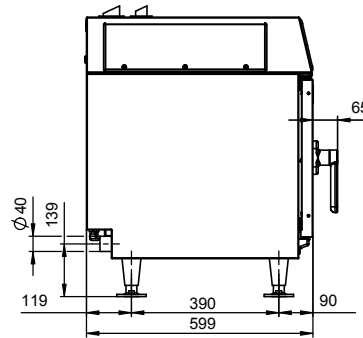

View from above with wall clearances

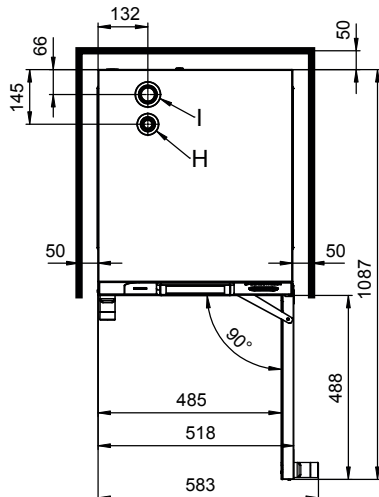

Connection points

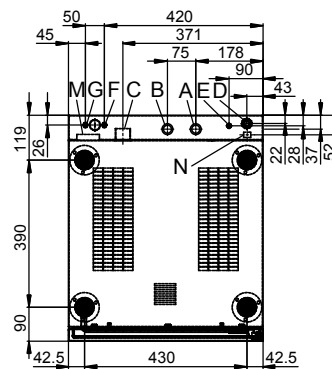

Rear view

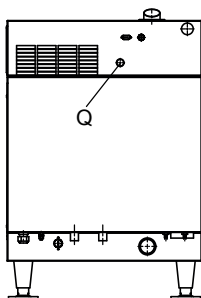

- A Water-supply connection (for water injection)
- B Water-supply connection (for cleaning)
- C Drain connection DN 40
- D Electrical connection
- E Equipotential bonding
- F Rinse-aid connection
- G Cleaning-agent connection
- H Air vent Æ 30mm
- I Dry air intake Æ 43mm
- M Safety overflow 60mmx20mm
- N RJ45 Ethernet port
- Q Safety thermostat reset

Dimensions and weights

Dimensions including packaging	
Width x Height x Depth	580 x 955 x 740 mm
Weight	
Empty weight without packaging	45 kg
Weight of packaging	12 kg
Safety clearances*	
Rear	50 mm
Right	50 mm
Left (larger gap recommended for servicing)	50 mm
Top**	500 mm

* Minimum distance from heat sources: 500 mm.

** Depends on type of air ventilation system and nature of ceiling.

Loading capacity

Max. number of food containers	
GN 2/3 depth 40 mm	6
GN 2/3 depth 65 mm	4
Plates max. Ø 28 cm,	4
Maximum loading weight	
GN 1/1, per combi oven	13 kg
GN 1/1, per shelf level	5 kg

Electrical supply

3~ 400V 50/60Hz (3/PE)	
Rated power consumption	5.7 kW
Convection power	5.4 kW @ 230V
Motor power	0.25 kW
Rated current	8.7 A
Fuse rating	16 A
Recommended conductor cross-section	5G2.5
3~ 440V 60Hz (3/PE)	
Rated power consumption	5.7 kW
Convection power	5.4 kW @ 230V
Motor power	0.25 kW
Rated current	13 A
Fuse rating	16 A
Recommended conductor cross-section	5G2.5
3~ 480V 60Hz (3/PE)	
Rated power consumption	6.7 kW
Convection power	6.4 kW @ 230V
Motor power	0.25 kW
Rated current	13.9 A
Fuse rating	16 A
Recommended conductor cross-section	5G2.5
3N~ 400V 50/60Hz (3/N/PE)	
Rated power consumption	5.7 kW
Convection power	5.4 kW @ 230V
Motor power	0.25 kW
Rated current	11.8 A
Fuse rating	16 A
Recommended conductor cross-section	5G2.5
3~ 230V 50/60Hz (3/PE)	
Rated power consumption	5.7 kW
Convection power	5.4 kW @ 230V
Motor power	0.25 kW
Rated current	23.5 A
Fuse rating	25 A
Recommended conductor cross-section	4G4

Water connection

Water supply	
Shut-off device	With EA (verifiable) check valve and dirt filter
Water supply	
	2 x G 3/4", Fixed connection recommended
Flow pressure, without ConvoClean system	
	200 - 600 kPa (2 - 6 bar)
Flow pressure, with ConvoClean system	
	300 - 600 kPa (3 - 6 bar)
Appliance drain	
Drain version	Fixed connection (recommended) or funnel waste trap
Type	
	DN 40
Slope for drain pipe	
	min. 5% (3°)

Water quality

Water-supply connection A* for water injection	
General requirements	Drinking water, typically soft water (install water treatment system if necessary)
General hardness	4 - 7 °dh / 70 - 125 ppm / 7 - 13 °TH / 5 - 9 °e
Water connection B* for cleaning	
General requirements	Drinking water, typically hard water
General hardness	4 - 20 °dh / 70 - 360 ppm / 7 - 35 °TH / 5 - 25 °e
Water-supply connections A, B*	
pH value	6.5 - 8.5
Cl ⁻ (chloride)	max. 60 mg/l
Cl ₂ (free chlorine)	max. 0.2 mg/l
SO ₄ ²⁻ (sulphate)	max. 150 mg/l
Fe (iron)	max. 0.1 mg/l
SiO ₂ (silicate)	max. 13 [mg/l]
NH ₂ Cl (monochloramine)	max. 0.2 mg/l
Temperature	max. 40 °C
Electrical conductivity	min. 20 µS/cm

* See diagram of connection points, page 3.

Water consumption

Water-supply connection A*	
Ø Consumption for cooking	0 - 15 l/h
Max. water flow rate	0.5 l/min
Water-supply connections A, B with ConvoClean system	
Ø Consumption for cooking**	0 - 20 l/h
Max. water flow rate	7 l/min

* Values for selecting the capacity of the water treatment system.

** Including water used for cooling the wastewater.

PLEASE NOTE: See diagram of connection points, page 3.

Emissions

Dissipated heat*	
Latent heat	1000 kJ/h / 0.28 kW
Sensible heat	1100 kJ/h / 0.31 kW
Waste water temperature	max. 68 °C
Noise during operation	max. 60 dBA

* The dissipated heat values were measured as per DIN 18873-1 "Methods for measuring the energy use of equipment for commercial kitchens — Part 1". The type and frequency of appliance usage are decisive for the specification of an air conditioning and ventilation system. These values can be higher than the values indicated for dissipated heat. Guide values can be found in the technical literature, e.g. in VDI 2052. Please consult your specialized design engineer for planning an air conditioning and ventilation system.

ACCESSORIES

(Please refer to the Accessories brochure for detailed information)

Stacking kits

Stacking kit unit

Permitted combinations mini 6.06 on the bottom, mini 6.06 on top

Please observe the following points:

- This document is to be used solely for planning purposes.
- Please refer to the Installation manual for further technical data and guidance on installation and positioning.